

The Arrow Antenna

Hit the bull's-eye with this portable VHF sharp shooter.

by Mike Walker KA0VFF and Al Lowe N0IMW

How would you like a completely portable, 4-element 2 meter antenna that fits into its own 1" x 1" x 48" boom? Not only does it fit inside its boom, but it can be assembled in approximately two minutes. I'll just bet you are quivering with excitement! Calm down and reach for a quiver of aluminum arrows. Aluminum arrows are the secret to the versatility and exceptional gain characteristics of the Arrow Antenna.

This antenna has proven to be very versatile. While hiking in the Rocky Mountain National Park, I used my antenna as a walking stick. During rest stops it was just a matter of pouring out the boom contents, taking a couple of minutes for assembly time, and I was on the air! In an emergency, this antenna is ideal. It will store easily in the trunk of your car, ready for any situation. Another advantage of the antenna is that it is not prone to damage because its contents are protected by the boom.

Foxhunting activities can be stressful to your antenna, especially during the heat of the chase. Your Arrow Antenna will be able to withstand lots of abuse, even when your partner drives under low-hanging tree limbs.

At every public service event, it seems like the check point assignments are in the worst possible locations. The Arrow Antenna will help you shoot your way out of those places where a rubber duck and an HT would not be sufficient. If you need antenna gain, portability, and a rugged antenna, then read on.

Another unique aspect of the Arrow Antenna is the gamma match. Al Lowe N0IMW is to be credited with the design of the gamma match. The gamma match makes the Arrow Antenna all the more portable. Al spent several long evenings fabricating prototypes of the gamma match before finalizing the de-



Photo A. The Arrow Antenna.

sign. When you start construction of this antenna, I am sure you will appreciate the cleverness of Al's design.

Construction

To begin construction of the Arrow Antenna you have the option of using our measurements, or to custom design your antenna for a specific frequency. Our design is not new. It is basically a copy of the standard NBS (now called the National Institute of Standards and Technology), with some variations. Our Arrow Antenna dimensions are calculated for a center frequency of 146.520 MHz. It is fairly broad-banded, having been tuned out of band for use in area search and rescue communication around 143 MHz and 149 MHz.

The materials for the antenna are readily available. If you are handy with a drill press and a hacksaw, you will have no problem building and assembling this antenna. See the Parts List for the materials needed.

Using a drill press for construction of this antenna will enhance the overall performance of your antenna. The mechanical integrity of your antenna will be a natural progression because the drill press will inherently keep all your elements parallel and perpendicular.

For our purposes, antenna performance dictated the selection of a 48" boom. Measuring from each end of the boom material, lay

out the reflector element, and the second director element at 1" from the end of the boom. Mount all elements in the center of the boom width. Place the driven element 15-5/16" inches from your first mark, or 16-5/16" from the end of the boom. The spacing is slightly less than 0.2 wavelengths. In a like manner, lay out the positions for the first director. The driven element and the first director will be spaced at approximately 15-5/16" in

the center of the boom. Now you have established all of your element locations (see Figure 4). At each of the element locations, drill a through-hole 11/64" in diameter for a #8-32 threaded rod.

Using the reflector as the reference for the rear of the antenna, move up to the driven element #8-32 hole location and establish the hole location for the PL259 bulkhead connector exactly 1" on center forward from the driven element, or 17-5/16" from the rear of the boom. The bulkhead connector requires a 5/8" through-hole. You should now have holes drilled for each of the elements, and the hole for gamma match and coax connections along the boom (see Figure 2). The desired polarization of your antenna will determine the location of the U-clamp. During our fabrication of the Arrow Antenna we placed the U-clamp at the balance point of the antenna. If you use the antenna in the vertical position it is imperative that the gamma match be above the boom and the coax run along the boom to the mast. If the coax is parallel, close to the driven element, antenna performance will suffer.

Each of the following measurements will be used to establish element lengths. Using a tubing cutter, scribe the outside of each element at the desired length. Grasping the element on either side of the scribe mark, you

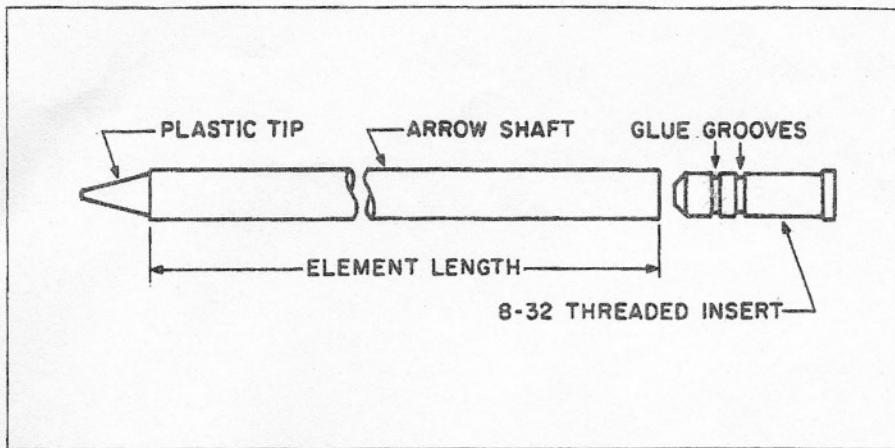

Figure 1. The aluminum arrow element.

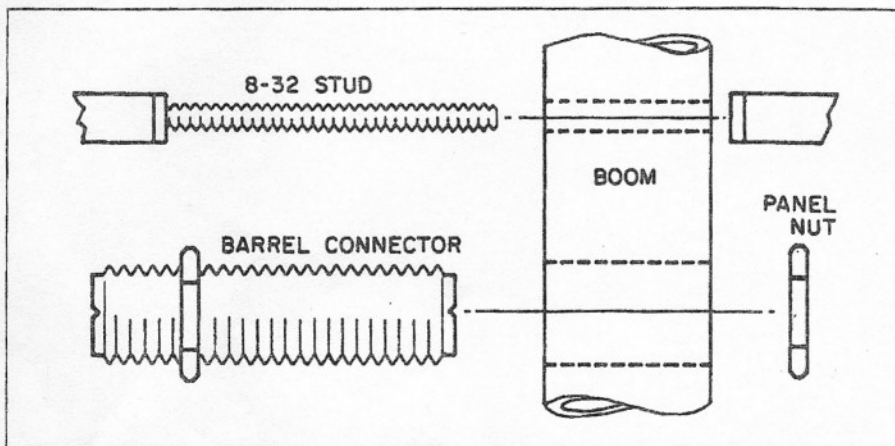

Figure 2. Attaching the elements to the boom. The feedpoint connection is also shown.

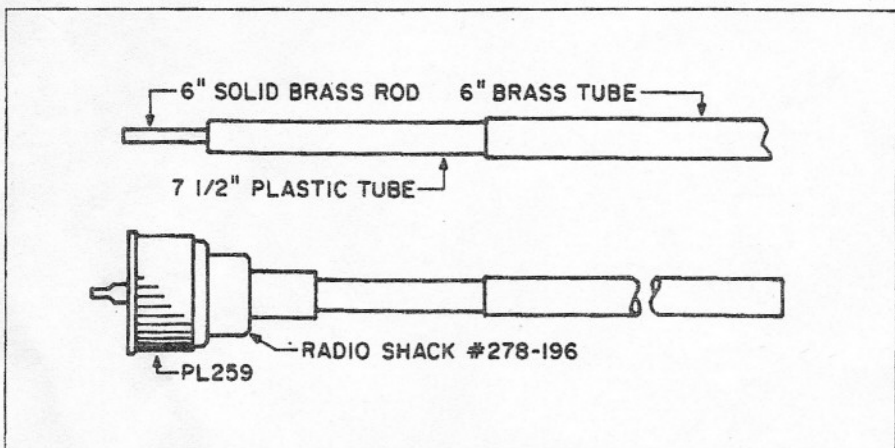

Figure 3. Preparing the gamma match.

will be able to precisely snap the element into two pieces, using the following element lengths: Scribe two arrows at 19-7/8", two at 19-1/4", two at 18-1/4", and two at 17-1/8". These pairs of elements will make up the reflector, the driven element, and the first and second directors, respectively.

The Easton EAGLE 1816™ arrow shafts that I used have conical plastic tips that are used for cementing on the nocks in normal arrow construction. The plastic tip should *not* be used when measuring the element length, but should be left intact in order to seal up the end of the element. When you purchase the arrow shafts from an archery supply store,

you will be given inserts that are used for attaching the field points to the arrow shaft. These inserts will be used for attaching the elements together and to the boom. When installing the inserts, apply a small amount of epoxy.

Please note that the boom width is not included as part of the calculation for overall element length. The element diameter will have an effect on element length, and I do not recommend exceeding the element diameters by more than 0.100". Many aluminum arrows are greater in diameter than the 1816 Easton EAGLE. The 1816 is the smallest arrow shaft that will accept the 8-32 threaded

insert. Our prototype antennas both used larger diameter arrows. The change to the 1816 was only a factor of cost.

Starting with the 19-7/8" reflector pairs, install one 8-32 threaded rod 1" into one of the element halves. In our construction, we used LOC-TITE™ to permanently affix the 8-32 x 3" rod into the arrow shaft. Install the remaining threaded rods into the other three element halves.

To fabricate the gamma match you will need a PL259 solderless connector, a 6" solid brass rod 0.080" O.D., a brass tube 0.180" I.D. x 0.240" O.D., and a plastic tube 0.175 O.D. x 0.080 I.D. 7-1.2". Solder the 6" brass rod into the center of the PL259, flush with the tip of the connector, just as you would for attaching RG-58 coax. Next, slide the 7-1/2" plastic tubing onto the 6" brass rod and cover the plastic tubing with the 0.180" I.D. x 0.240" O.D. brass tube. This assembly is now your gamma match. To complete the assembly you will need to epoxy the plastic tube into the connector. After tuning the antenna, you may want to tape the brass tube in position, and mark the position of the shorting bar for convenient setup in the future.

To make the shorting bar for the gamma match you will need a small piece of aluminum 1.5" x 0.5" x 0.5" (see Figure 5). Measure and mark a place on the aluminum block 1/4" from one end and 1/4" from the edge of the block. This should place your mark along the center of the width of the block. Measure exactly 1" from the previous mark and again center this mark along the width of the block. Drill a hole 7/32" through at your first mark and drill a through hole 9/32" at the second mark. Standing the block on end, drill a 0.201" hole into the 0.5" x 0.5" block end, keeping the hole centered in relation to the block. Drill into each end of the block until the drill bit is visible through the previously-drilled 7/32" and 9/32" holes. Tap the two end holes for a 1/4"-20 thread. Two 1/4"-20 bolts will be used for setscrews to attach the shorting bar between the gamma match and the driven element.

Assembly

The Arrow Antenna is now ready for assembly. Place the threaded end through the 11/64" hole in the boom and screw on the other half of the element. (See Figure 4 for the correct placement of the elements). Continue down the boom, installing the rest of the elements. Screw the bulkhead connector onto the gamma match, then screw one of the panel nuts flush to the gamma match. Now insert this assembly through the 5/8" hole forward of the driven element, tightening it in place with the bulkhead panel nut. Attach the shorting bar over the end of the driven element that is parallel to the gamma match. Slide the bar along the element until you reach the end of the gamma match, and slide the shorting bar onto the end of the gamma match. Using the 1" x 1/4"-20 bolts, fasten the shorting bar so that it is flush with the end of the gamma match. Connect the coax to the other end of the bulkhead connector. Mast-mount your antenna and route your coax so

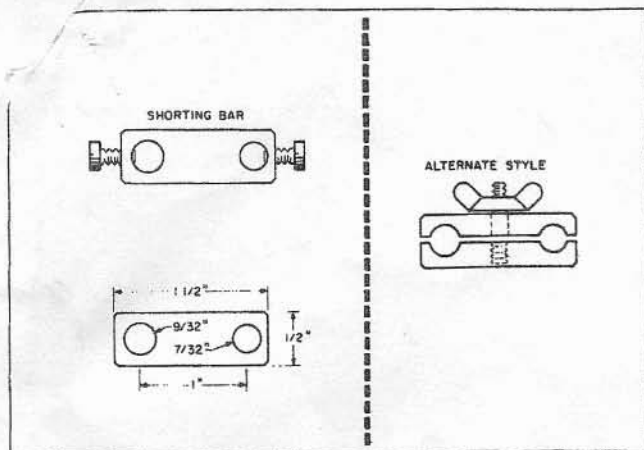

Figure 5. Two alternatives for the gamma match shorting bar.

that it is close to the boom and mast. You are now ready to test and tune your antenna.

Testing and Tuning

The antenna is tuned by sliding the outer brass tube out and moving the shorting bar along the gamma match assembly and test for the best SWR. In our experience, the antenna should be within acceptable limits of $1.3:1$, if the assembly has been constructed carefully. Our antennas have all tuned to an SWR of 1.1:1 at 146.520 MHz.

Disassemble the antenna and screw the element pairs together. Install one of the 1-1/4" crutch tips onto one end of the boom. Insert the bundle of the four element pairs into the boom. Drop in the gamma match and shorting bar. Install the second crutch tip, and you're ready to go portable.

NOTE: For permanent installation, I recommend that star washers be installed when attaching the elements to the boom. The addition of star washers should keep the elements from vibrating loose. Normal care should be taken to weatherproof your antenna. Seal the coax connection and the end of the gamma match assembly.

We Won a Respectable Second Place

I entered the antenna in the 1991 Dayton Hamvention VHF antenna competition. Al N01MW and I both wondered how the Arrow Antenna would measure up. We were not disappointed with the results; in the homebrew category, the antenna measured 6.1 dB gain over the reference dipole used for testing.

The winning antenna was 35' long with 19 elements and 14.3 dB gain over the reference dipole. Al and I will be looking forward to Dayton '92. We will be ready to compete again.

I was fortunate to have John Wood KC0WA as my mentor for antenna construction. Because of John's encouragement and help during our antenna experimentation, the Arrow Antenna evolved to its present form.

You may contact Mike Walker KA0VFF at 3816 Ash Avenue, Loveland CO 80538.

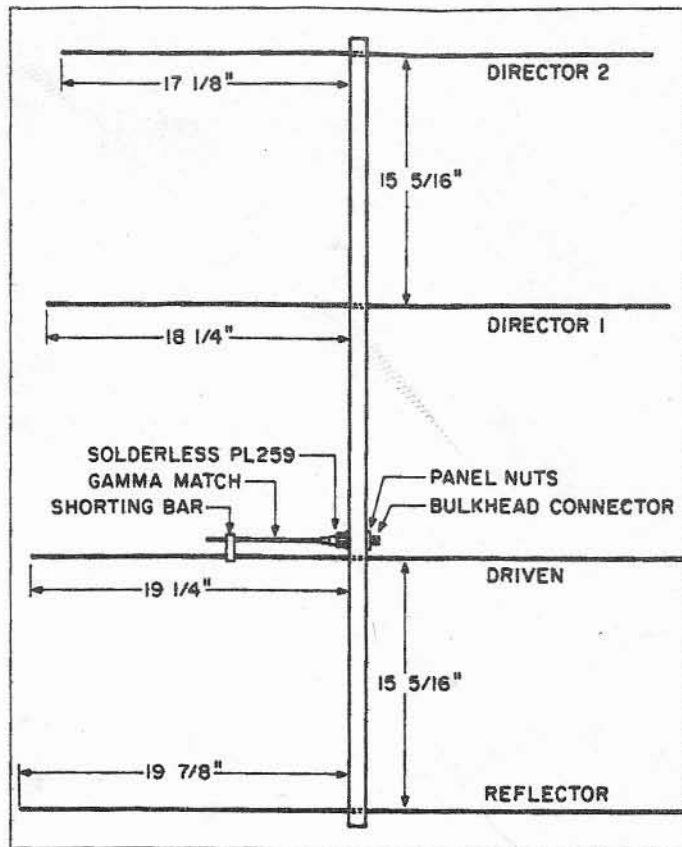

Figure 4. The overall dimensions of the completed Arrow Antenna.

The Arrow Antenna		
Specifications	Configuration	Yagi
	Number of elements	4
	Matching System	Gamma
	Boom Diameter	1" square, aluminum
	Boom Length	4' Element Material 7075 aluminum (Arrow Shafts)
Gain	Measured (forward)	6.1 dB over reference dipole (estimated over 9 dBi)
	Measured (front-to-back)	10.1 dB
	Note for direction finding: This makes the signal peak directly off the front and the deepest null directly off the back of the antenna.	
Special Features	Portable	All antenna hardware fits inside the boom for storage or transport.
	Assembly time	Less than two minutes
	Weight	24 oz.
	Bandwidth	4 MHz (144-148)
	SWR over band width	< 1.5:1
	SWR at 146.52	< 1.1:1
Parts List		
1	1" x 1" x 48" piece of square aluminum tubing (NOTE: The wall thickness of our square tubing was 0.0625" allowing us to pack all the antenna hardware inside the boom.)	
8	Aluminum arrows >20" in length, and approximately 9/32" in diameter	
1	2" PL259 bulkhead connector w/panel nuts	
1	Solderless PL259 Radio Shack #278-196	
1	Male PL259 90-degree connector (optional), Radio Shack #278-199	
1	6" x 0.080" diameter brass rod	
1	7-1/2" x 0.080" I.D. x 0.175" O.D. plastic tube	
1	6" x 0.180" x 0.240" O.D. brass tube	
2	1-1/8" diameter rubber crutch tips	
4	#8-32 x 2-1/2" pieces of threaded rod	
2	1/4"-20 x 1" bolts	
1	0.5" x 0.5" x 1.5" aluminum bar	
The Arrow Antenna is available ready-made for \$65 plus \$5 postage and handling. Send a check or money order to Mike Walker KA0VFF at 3816 Ash Avenue, Loveland CO 80538. Telephone: (303) 669-2697.		